

HUDSON

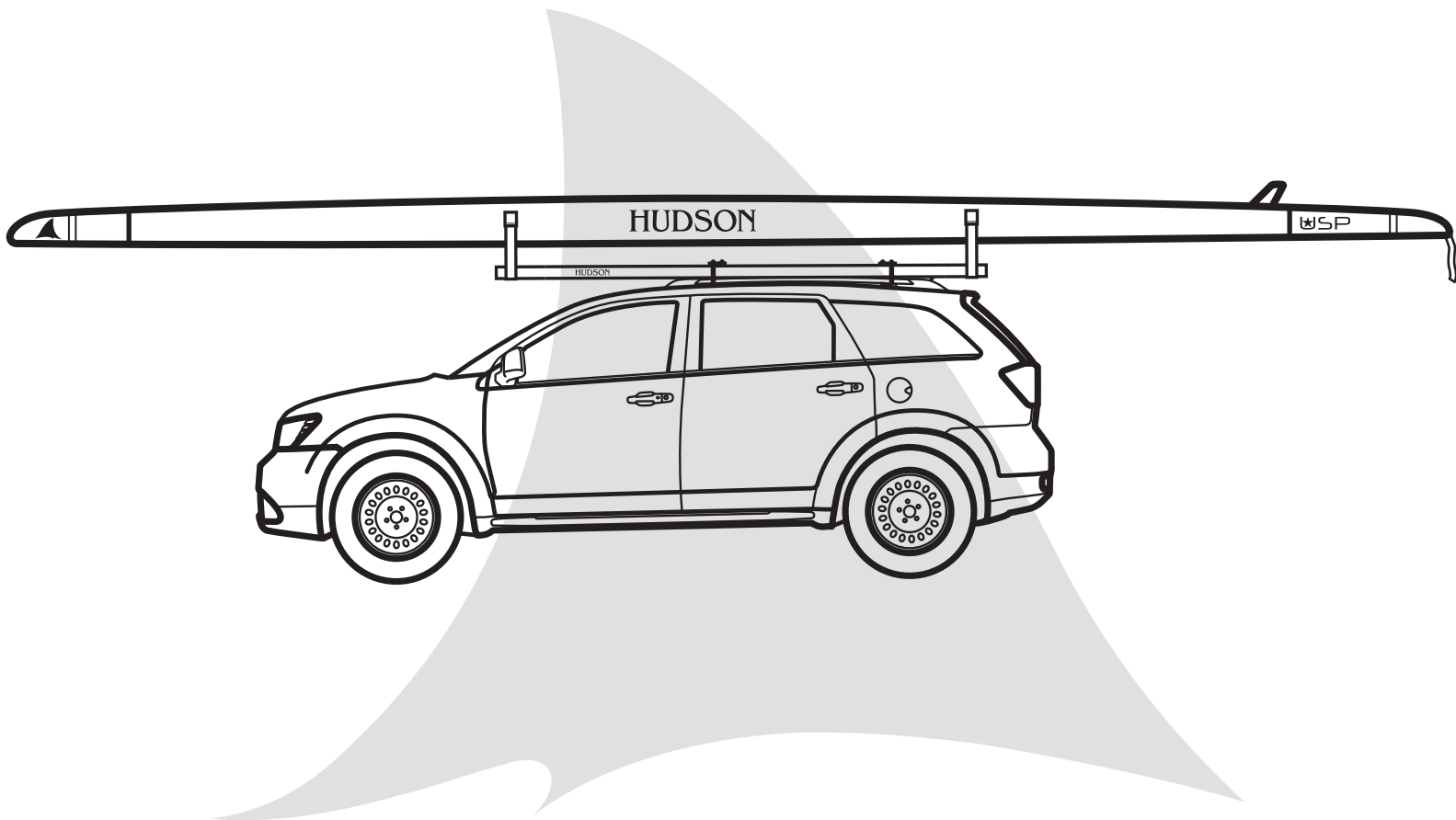

Ix Roof Rack Installation Manual

[Rev.11.20]

MATERIALS

HUDSON 1X Roof Rack Kit includes:

- 1 – 2.75m aluminum base rack
- 2 – V-shaped slings
- 4 – M6 bolts
- 4 – M6 Nylock nuts (slings)
- 2 – Nylon end caps
- 2 – Black shoelaces
- 2 – Set of U-bolts (Small / Large)
- 2 – Plates
- 4 – M10 Nylock nuts (racks)

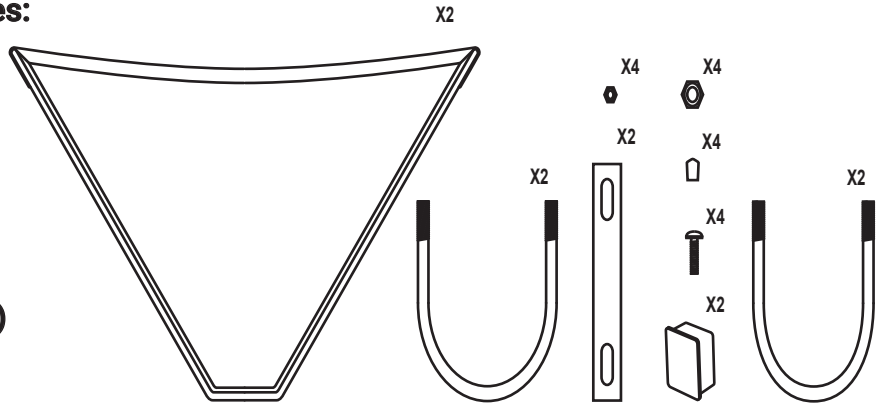

Figure 1: Rack Components.

Additional Materials (NOT INCLUDED) Needed for Assembly:

- (1) 17mm wrench
- (1) 5mm Allen Key
- (1) 10mm Wrench
- Factory issued or aftermarket Roof Rack for Vehicle*

*HUDSON recommends using an aftermarket roof rack (ex: Thule or Yakima).

ASSEMBLING THE RACK

STEP 1: Find a clear space on a surface* to assemble the rack BEFORE mounting it on the vehicle. Place the V-shaped slings upside down on the surface, and line the middle holes of the boxed aluminum up with the holes in the V-shaped slings.

**SURFACE SHOULD BE CLEAR AND MINIMALLY ABRASIVE TO PREVENT PREMATURE WEAR ON RACK.*

STEP 2: With one hand place, your index finger over the box end of the 17mm wrench, and place one of the M6 Nylock nuts in the box end (underneath your finger). Slide the finger with the wrench and the nut into the boxed aluminum end, and line the nut up with the middle hole. Raise the end of the box aluminum base rack to the V-shaped sling holes, and line them up. Using your other hand, manually thread the M6 bolt (see Fig. 2). Repeat this step to thread the second nut to the second bolt.* Take the shoe lace and tie it around the webbing and the bottom of the rack. This will prevent flapping (wear) of the webbing when a boat is not on the rack.

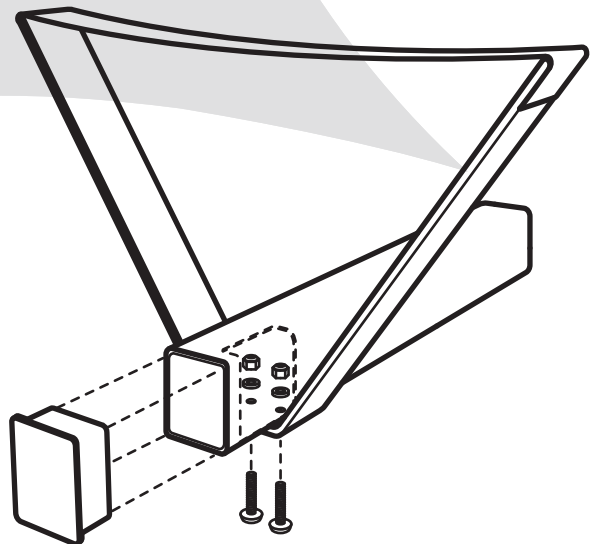

Figure 2: Securing sling to single rack.

**DO NOT TIGHTEN UNTIL BOTH NYLOCK NUTS HAVE BEEN LINED UP/FASTENED TO THE BOLT.*

STEP 3: As you tighten the Nylock nut, you should feel the bolt threading through the nut on your fingertip. Continue to keep upward pressure on both the wrench and the nut/bolt to keep the wrench from slipping. Once you are confident both bolts are tight, place the end cap on, and repeat the process on the other end.

STEP 4: You're now ready to mount the rack onto the roof rack of your vehicle*! Begin by spacing your roof rack as wide as possible, front to back. The wider spaced the roof rack is, the less force a sudden gust will have on the rack. (See Fig.4).

**DETERMINE BEST LOCATION BEFORE SECURING RACK. CONSIDER SUNROOFS, MOONROOFS AND TRUNK.*

Transporting 1x NO RIGGER:

Mount single rack close to feet of the roof rack.

Transporting 1x WITH RIGGER:

Mount single rack in the middle of the roof rack.

STEP 5: Once you have determined the best location for the rack, choose the appropriate (smallest) sized U-bolt for your rack from the provided options. Use the chosen U-bolt and Nylock nuts to secure your single rack to the roof rack on the top of your vehicle (See Fig. 3).

STEP 6: With the hull upside down on the single rack, put a strap around the boat and the roof rack approximately 10cm from the sling. Ensuring that the strap is flat all the way around, feed the end through the cam and draw the strap through the cam until the boat is secure*. Then tie both sides of the strap together, by looping around the other side and creating a knot just below the cam. Repeat with a second strap on the opposite sling.

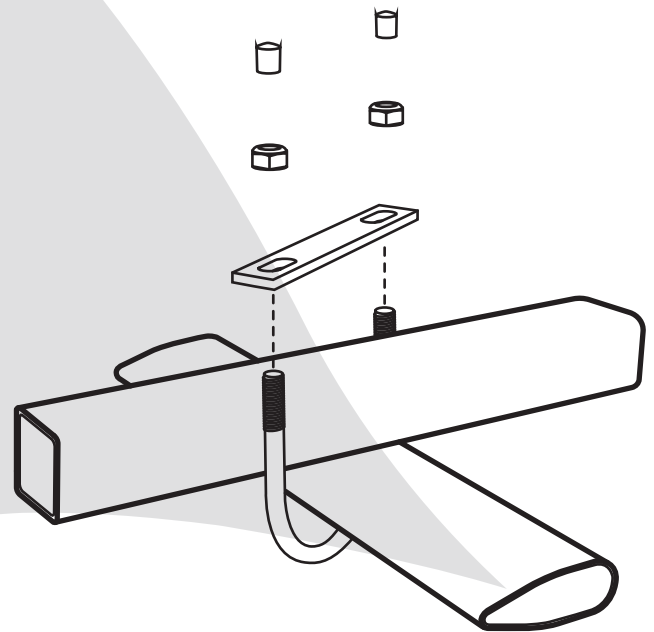
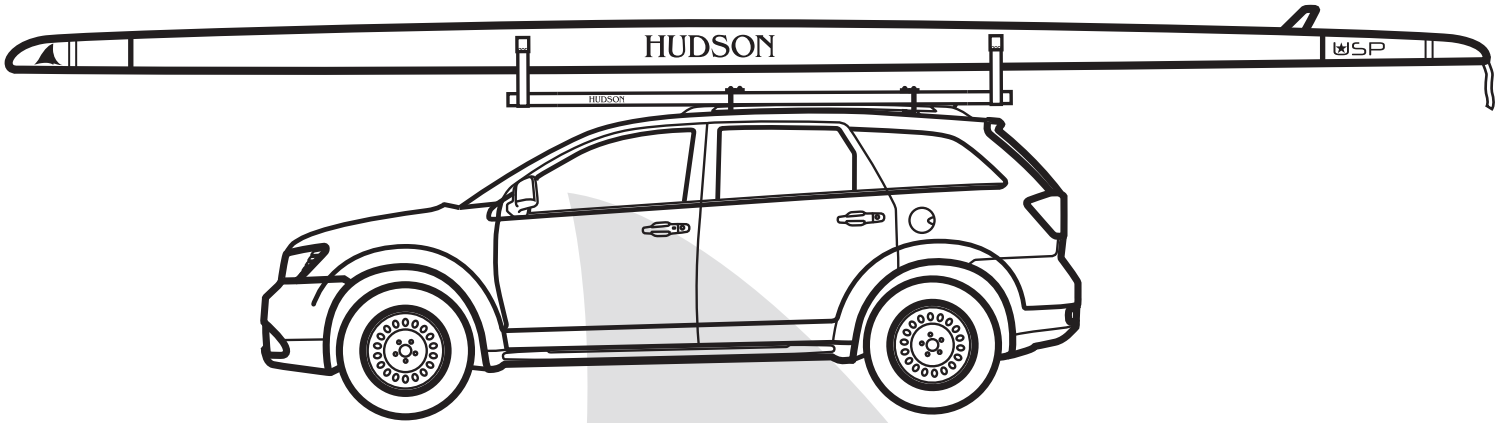

Figure 3: U-Bolt Assembly.

**OVERTIGHTENING OF THE STRAPS CAN CAUSE DAMAGE TO THE HULL. IT SHOULD BE SECURE BUT NOT COMPRESS THE EXTERIOR OF THE HULL.*

Figure 4: Different Vehicle Model Examples for Rack Location.



SUV

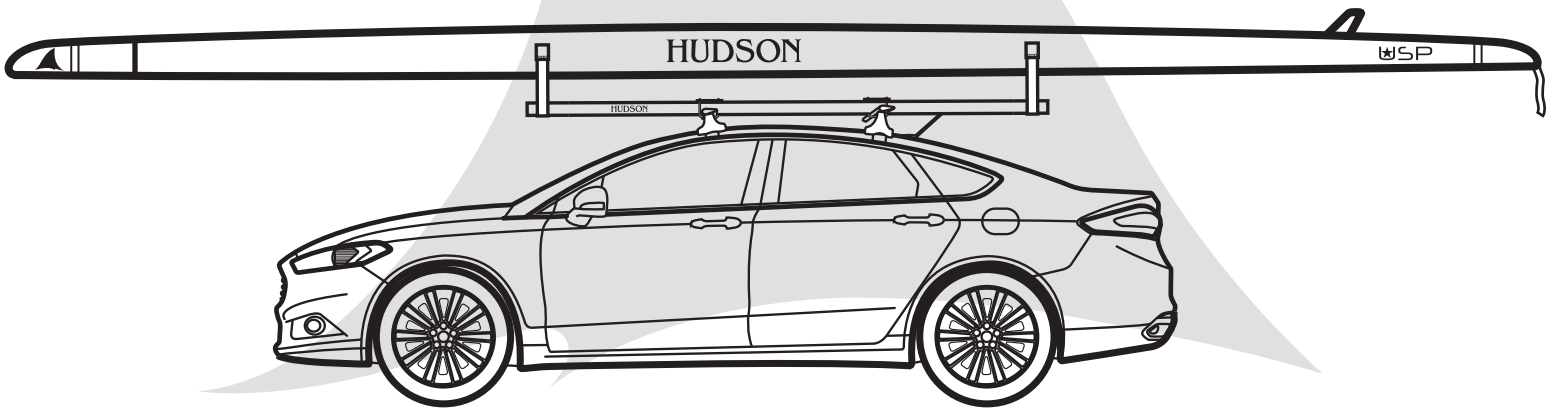

SEDAN

PRIOR TO TRAVELING:

CHECK YOUR RESPECTIVE STATE/PROVINCE FOR THEIR OVERHANG LAWS AND SAFETY FLAG REQUIREMENTS – THEY DO DIFFER! THIS MAINLY REFERS TO THE AMOUNT OF OVERHANG OFF THE REAR OF THE VEHICLE.

STRAPS, SLINGS AND BOLTS SHOULD BE CHECKED BEFORE ANY TRAVEL OCCURS TO MINIMIZE RISK OF DAMAGE OR LOSS OF EQUIPMENT. SLINGS AND/OR STRAPS SHOULD BE REPLACED AT THE FIRST SIGN OF FRAYING OR SIGNIFICANT WEAR.

**Contact HUDSON with any questions or concerns.
A HUDSON representative will be more than happy to help!**

#BEASHARK

**Hudson Boat Works Inc.
2519 Fanshawe Park Road East
London, Ontario, Canada N5X 4A1
(519) 473-9864
www.hudsonboatworks.com**